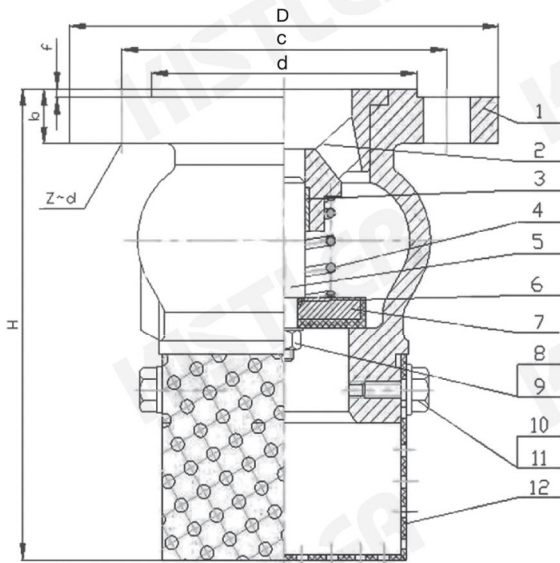

**Fig. FV-801D (ANSI150)
FV-802D (JIS10K)
FV-803D (PN10)
FV-804D (PN16)**

Ductile Iron, Epoxy powder coated body
Stainless steel strainer



PRESSURE-TEMPERATURE RATINGS

Working Pressure	10 bar
Test Pressure	16 bar
Service Temperature	80°C

MATERIALS

NO.	NAME OF PARTS	MATERIAL
1	Body	Ductile Iron (A536, FCD450, GGG40)
2	Bonnet	Ductile Iron (A536, FCD450, GGG40)
3	Bush	Brass A124-C37700
4	Spring	Stainless Steel 304 (CF8, SCS13)
5	Guiding Stem	Stainless Steel 2CR13
6	O-Ring	NBR
7	Disc	NBR cover Ductile Iron
8,9,10,11	Nut,Washer	Stainless Steel 304 (CF8, SCS13)
12	Sleve	Stainless Steel 304 (CF8, SCS13)

TECHNICAL FEATURES

- Operates in any position from horizontal to vertical ascending or oblique pipelines to allow flow in onedirection.
- Minimum head loss. silent, reliable sealing and various type available NBR/EPDM/VITON/PTFE.
- Simple and robust-design suitable for general applications. Does not generate hammering.

DIMENSIONS

Unit : mm

SIZE inch.	H	JIS10K			ANSI150			PN10			PN16		
		D	C	N	D	C	N	D	C	N	D	C	N
2"	170	155	120	4	152	121	4	165	125	4	165	125	4
2.1/2"	200	175	140	4	178	140	4	185	145	4	185	145	4
3"	220	185	150	8	191	152	4	200	160	8	200	160	8
4"	265	210	175	8	229	191	8	220	180	8	220	180	8
5"	300	250	210	8	254	216	8	250	210	8	250	210	8
6"	360	280	240	8	279	241	8	285	240	8	285	240	8
8"	470	330	290	12	343	299	8	340	295	8	340	295	12
10"	570	400	355	12	406	362	12	395	350	12	405	355	12
12"	655	445	400	16	483	432	12	445	400	12	460	410	12
14"	670	490	445	16	533	476	12	505	460	16	520	470	16